

# SGA1 SINGLE CYLINDER KNIFE VALVE

SLIDE GATE VALVES SGA1 are designed to shut off the flow of product from outlets of dry bulk storage bins, silos, conveyors and other discharge points.

SGA1 is used where dust sealing is requested. The self-calibrated spring ensures the valve a long durability and reduces SGA1 wear and tear. Slide gate valve is suitable for the most demanding applications on market.



## APPLICATIONS

- GRAVIMETRIC FLOW
- POWDER
- GRANULE
- PELLETS
- MOCA – EC1935/2004

## DESIGN

- SIZE: DN 150, DN 200, DN 250
- BODY: CASTING ALUMINIUM
- BLADE: SS304/SS316L
- MAIN SEAL: NOVATRON
- OPERATION: SINGLE CYLINDER, HANDWHEEL

## OPTIONALS

- SPECIAL EXECUTION FOR ABRASIVE PRODUCT
- MATERIAL ACCORDING WITH EC1935/2004
- VARIOUS CHEMICAL TREATMENT ON BODY/FLAP
- VARIOUS SEAL MATERIAL
- HIGH TEMPERATURE VERSION
- CUSTOM SIZE

## FEATURES

- PRESSURE: ATM, 1 BAR
- TEMPERATURE: MAX 100 °C
- RUGGED DESIGN
- LONG LIFE

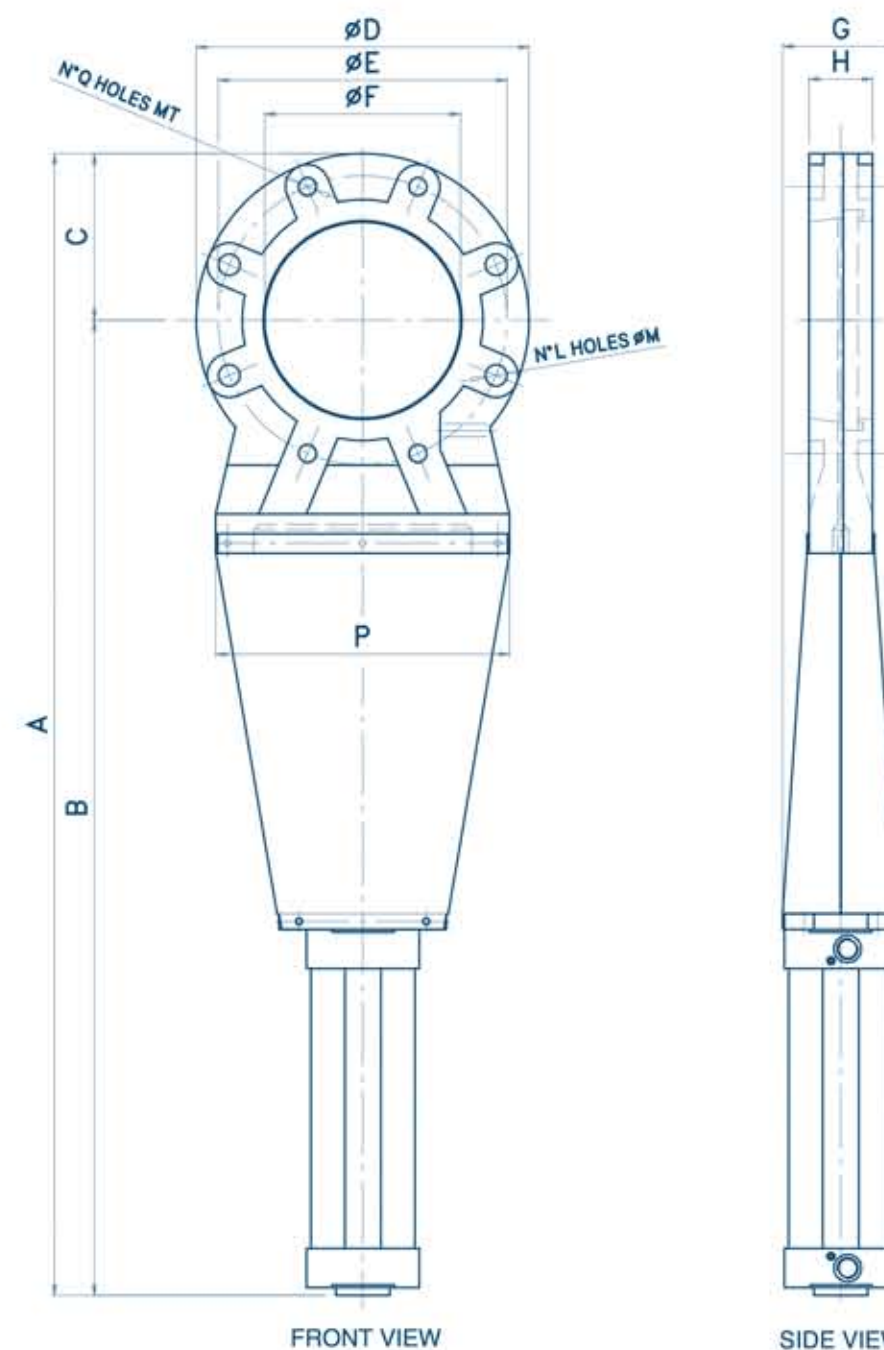

	A	B	C	D	E	F	G	H	L x ØM	P	Q x MT
150	935	795	140	280	Ø240	Ø153	115	65	4 x Ø22	270	4 x M20
200	1130	960	170	340	Ø295	Ø200	115	65	4 x Ø22	300	4 x M20
250	1325	1130	195	390	Ø350	Ø254	140	65	6 x Ø22	360	6 x M20

BROCHURE



COMPLIANCE



II 3D IIC T135°C Dc X